

Zwischenflanschrückschlagklappe Baureihe ARTRKEE

- Size :** DN40 to DN600
- Connection :** Between flanges PN10/16 according to DN Class 150 (PN20) from DN100 to 400
- Min Temperature :** -10°C
- Max Temperature :** +180°C
- Max Pressure :** 16 Bars up to DN200, 10 bars over
- Specifications :** FKM seat
Horizontal or vertical position with ascendant fluid
Wafer type
Removable hoisting eye
Weak headloss

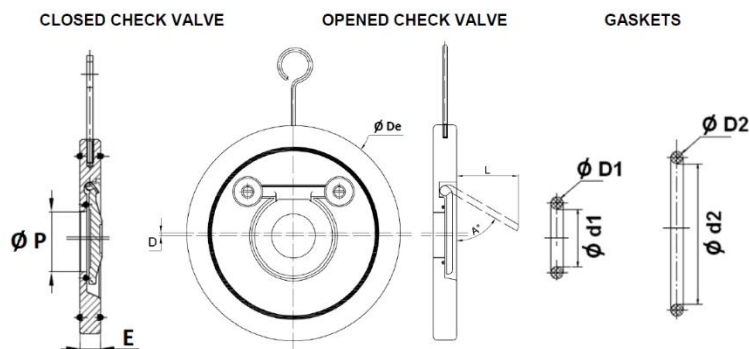

Materials : Stainless steel ASTM A351 CF8M



DN	40	50	65	80	100	125	150	200	250	300	350	400	450	500	600		
E	14	14	14	14	18	18	20	22	26	32	38	44	50	56	62		
Ø De	94	109	129	144	164	194	220	275	331	386	446	497	557	619	736		
Ø P	22	32	40	54	70	92	112	154	192	227	270	315	358	410	490		
L	24.5	33	32	47.7	70.4	93	112	149.3	171.9	225.7	229.6	268.2	296.7	329.5	434.8		
A (°)	54	54	34	43	55	60	59	58	53	61	48	48	46	46	54		
D	1	1	2	3	3	5	5	5	6	10	12	12	12	12	14		
Ø d2	70	80.5	100	107.5	134.5	158	186	240	284	328	385	435	486	534	630		
Ø D2	3.8									6	8						
Ø d1	24	34	46.5	59	72.5	93	113.5	156.5	194.5	231	283	328	375	426	510		
Ø D1	3				3.8						6	8					
Weight (Kg)	0.68	0.9	1.27	1.53	2.47	3.42	4.8	8.7	14.03	25.1	31.5	47	70	96	135		

Zwischenflanschrückschlagklappe Baureihe ARTREE

Item	Designation	Materials
1	Body	ASTM A351 CF8M
2	Disc	
3	Seat	FKM
4	Gasket	FKM

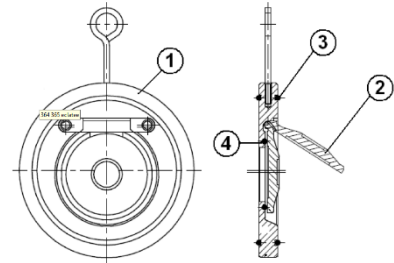

INSTALLATION POSITIONS :

Vertical position (ascendant fluid)

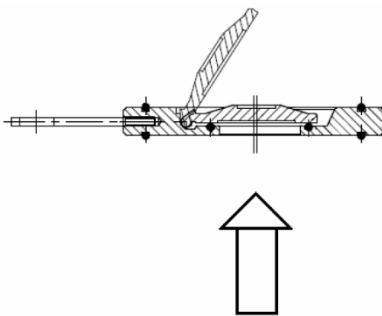

Horizontal position

